

DC AUTO STOP GEN2 WINCH BOX OWNERS MANUAL



WWW.LIFTTTECHMARINE.COM

Autostop:

To set or to change the Autostop positions please refer to the included Autostop manual.

Control Panel:

The control panel works the same as the remote controls: press UP to go up, DN to go down, and the light button to turn the canopy light on or off. When plugged into power, the READY light will blink green and the Bluetooth symbol will blink blue; once a phone is paired via Bluetooth, the symbol turns solid blue. When the Autostop is set the READY light will be solid green. The STATUS light turns solid red whenever any button is pressed. To lock or unlock the control panel, hold the lock/unlock button until all LED lights blink together (about 10–15 seconds); when locked, the lights will blink briefly and then go out. To unlock, hold the button again until the lights stop blinking. When locked, the control panel and remotes will not function, and pressing any button will cause all three lights to flash; however, the Bluetooth app will still work. **If the control panel is locked the 3 lights will flash when you press any button. If the lift will not move and the READY light is a solid green try clearing the Autostop settings.**

Remote Controls:

If the remote controls stop working but the control panel still functions—or vice versa—simply unplug the motor from the battery for two minutes. If functionality returns afterward, it means the system entered a safety mode due to overcharged battery (or batteries).

Power Outage:

In case of a power outage, use the provided back up bit (inside floatie) on the end of the shaft with your drill. Visit our website to watch a video on how to use the back up bit.

Power Requirements:

This DC Motor can be 12 volts or 24 volts. If running 24 volts make sure to hook your batteries up in a series. See image on right. We recommend 24 or 27 series deep cycle batteries. **Always disconnect power when lift is left unattended. Do not cover the motor in a plastic bag over the off season—it traps condensation and voids the warranty.**

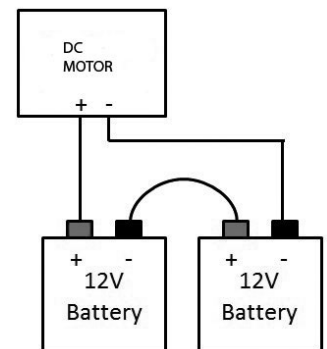

Maintenance:

Our motors are self-lubricating and do not need any maintenance. We do recommend to lubricate the chains once a year inside the winchbox. Solar Panels will evaporate water so make sure to check water levels in the battery to prevent battery damage and possible battery explosion. We recommend all solar panels use a charge regulator to prevent over charging. They can be purchased separate.

Troubleshooting:

Always start by unplugging the unit for 2 minutes. This will allow the circuit board to reset. Go to liftechmarine.com for more information, troubleshooting and how to videos.

Website:

Go to www.liftechmarine.com for more information, troubleshooting and how to videos.

The Lift Tech Auto Stop unit is designed to automatically stop the lift at user defined upper and lower limits, preventing accidental over travel and any potential damage. When the lift is commanded to go up and the lift reaches the upper limit, the lift will stop and will not allow any further upward travel. Likewise, when the lift is going down and the lower limit is hit, the lift will stop and not allow any further downward travel to occur.

If power is removed, the Auto Stop unit will remember the position limits, so there is no need to reprogram them. If you use the back up bit to move the motor you will need to clear the limit positions as they will now be in different spots.



GREEN LED LIGHT:

When no limits are set the Green LED light will blink fast. When one limit is set the green led light will change to a brighter fuller blink. When both limits are set the Green LED light will stay solid. After you press the lock button to set one of the limits watch the Green LED light to make sure it changed. If it changed this means it has accepted the limit.

CONTROL PANEL:

If the control panel is locked the motor will not move. See included instructions in owners manual.

TO SET THE TOP TRAVEL LIMIT POSITION:

Press the UP button on the remote until the lift moves to the desired upper limit.
Press the LOCK button on the remote to define the upper position.

When one position is set, the Green LED will blink Brighter.

TO SET THE BOTTOM TRAVEL LIMIT POSITION:

Press the DOWN button on remote until the lift moves to the desired lower limit.
Press the LOCK button on the remote to define the lower position.

When both position are set, the Green LED will always be on.

TO RESET POSITION LIMITS:

To clear position limits press the following key sequence on the remote or control panel: LOCK, LOCK, LIGHT. Make sure to press the buttons firmly for 1-2 seconds. If it doesn't work, try it again this time slower. Once the sequence is accepted, the Green LED light will change from always on to a quick blink.

TROUBLESHOOTING TIPS:

If your lift will not operate or go past a certain position try resetting the limits. We also have how to videos on our website. www.lifttechmarine.com

**If your neighbors have a Lift Tech Marine unit make sure they're not using their lift while you're programming.* The app will not work in Dark Mode.*

1. Go to the App store and search for Lift Tech and download the app. Once the app is downloaded on your phone, open the app and continue.

2. To activate the Bluetooth pairing sequence hold the UP and DN buttons on the control panel at the same time until the blue LED stays solid (picture below).

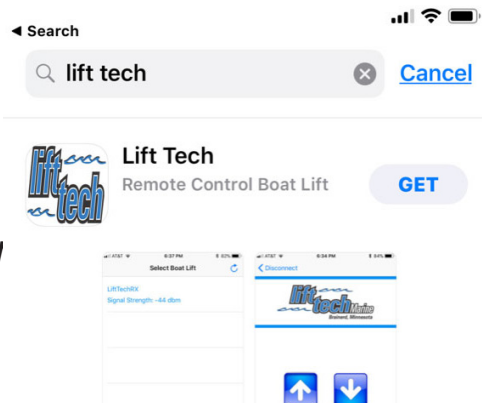

3. After you have activated the bluetooth sequence look at your phone and Tap the  button in the upper right hand corner of app. (See pic 2) LiftTech should now appear like in (pic 3). Tap on the Lift Tech Signal Strength and the screen should now look like (pic 4). Now tap on the pair option. 4. Once paired and connected to a Lift Tech receiver, the screen similar to (pic 5) will show the remote control options. 5. To rename your lift tap on Rename in the top right corner of the phone app.

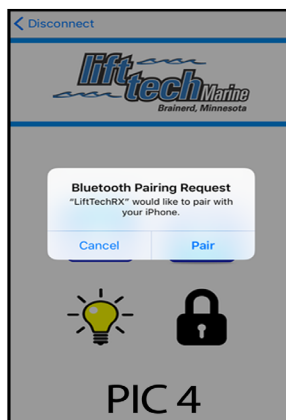
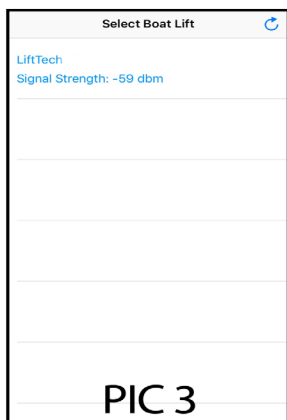
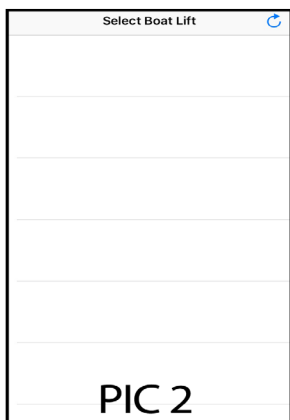

6. **UP**..... Pressing and holding this button will raise the lift.
DOWN.... Pressing and holding this button will lower the lift.
LIGHT..... Pressing this button will turn your canopy light on or off.
LOCK..... Hold for 5 seconds to lock or unlock the control panel.

NOTE: When done operating the lift, for security and IOS battery purposes, it is advised to disconnect from the Lift Tech receiver. To do this tap <disconnect in the upper left corner to be returned to the screen shown in pic 3.

If your neighbors have a Lift Tech Marine unit make sure they're not using their lift while you're programming.

1. Go to Google Play and search for Lift Tech Marine and download the app. Once installed open the app.

2. To activate the Bluetooth pairing sequence hold the UP and DN buttons on the control panel at the same time until the blue LED light turns solid. (See picture below). You will have around 15 seconds to add your phone. If the blue LED starts to blink, repeat the steps.

3. Press the scan button on the top right of your phone. (See PIC 1)

4. When the phone finds the motor it will look like PIC 2.



5. Press on the Lift - Signal Strength that comes up on the phone to pair it.

6. Once the phone is paired it will look like PIC 3. You are now done pairing your phone with the control panel. If you want to rename your lift simply press the rename tab on the top right of the app and a box will come up like in PIC 4. Rename it to what you want and hit Rename to save it.



PIC 1



PIC 2

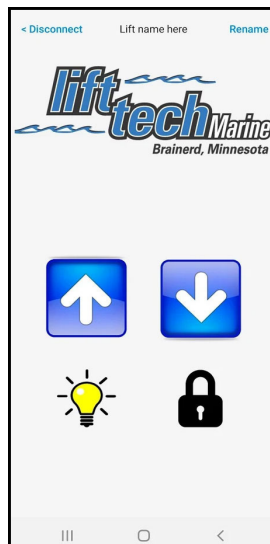

PIC 3

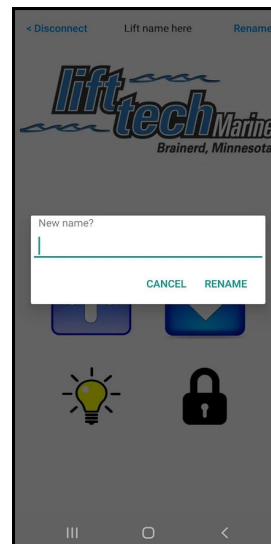

PIC 4

7. **UP**..... Pressing and holding this button will raise the lift.
DOWN..... Pressing and holding this button will lower the lift.
LIGHT..... Pressing this button will turn your canopy light on or off.
LOCK..... Hold for 5 seconds to lock or unlock the control panel.

Warranty Registration



*All Warranty registrations must be filled out within 60 days of purchase along with a copy of the original receipt for the warranty to be valid.

PRODUCT PURCHASED: AC IS PLUGGED IN TO EXTENSION CORD - DC IS BATTERY POWER.

AC MANUAL ALL IN ONE WINCHBOX

DC MANUAL ALL IN ONE WINCHBOX

AC REMOTE ALL IN ONE WINCHBOX

DC REMOTE ALL IN ONE WINCHBOX

AC AUTOSTOP ALL IN ONE WINCHBOX

DC AUTOSTOP ALL IN ONE WINCHBOX

Serial Number located on the motor cylinder: _____

Purchase from: _____

Name: _____

Address: _____

Email: _____ Phone: _____

Lift Tech Marine warrants our motor and winch from defects in materials and workmanship under normal use for a period of 2 years from the date of purchase. During the warranty period, Lift Tech Marine will repair the motor or winch if defective. The warranty does not include labor or shipping to us. The warranty is limited to the original purchaser and is not transferable. Warranty is void if the product is modified or altered.

Email this form and your receipt to :
customerservice@lifftechmarine.com

Or mail to:
Lift Tech Marine
7958 Hastings Road
Baxter, MN 56425

Visit our website to explore optional accessories.

www.lifftechmarine.com

ONLINE REGISTRATION

Scan the QR code to register the warranty online.

